

MATERIALEN

- Staalwikkelt: S235JR
- Staalwikkelt ankers: staal 8.8
- Staalwikkelt bouten, moeren en rondzels: staal 8.8
- Lassen: a=4mm tenzij anders vermeld
- Staalnetten: 50x50x4, verzinkt

BEHANDELING

STRUCTUUR:

- Thermisch verzinkt volgens NBN-EN-ISO 1461:2009

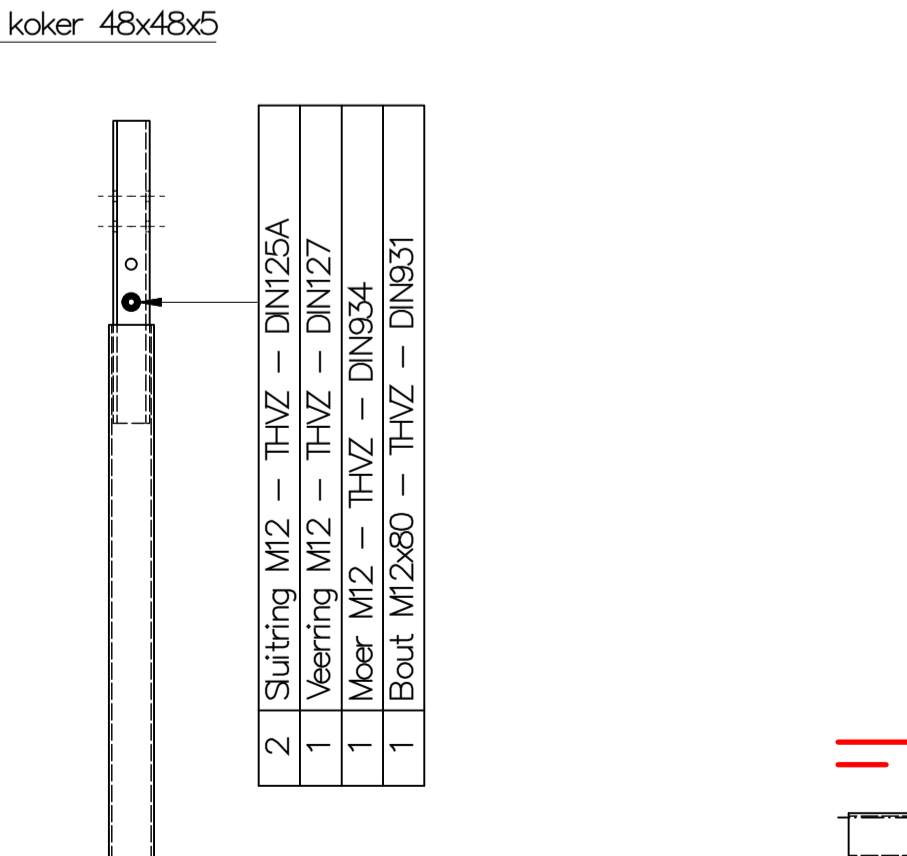
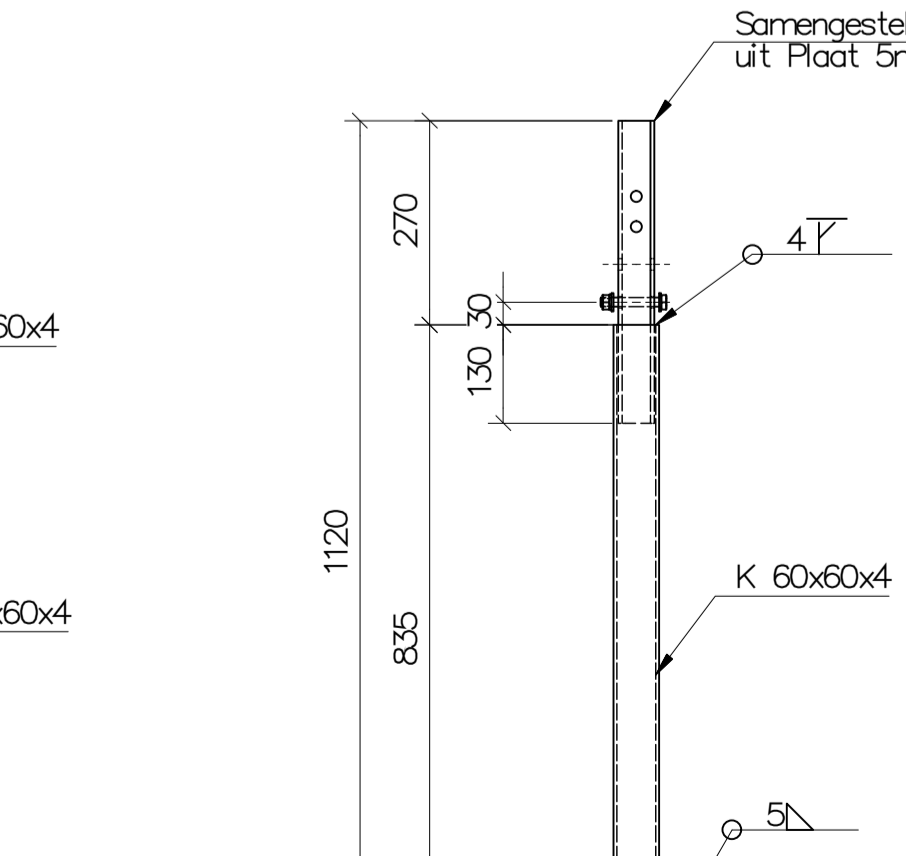
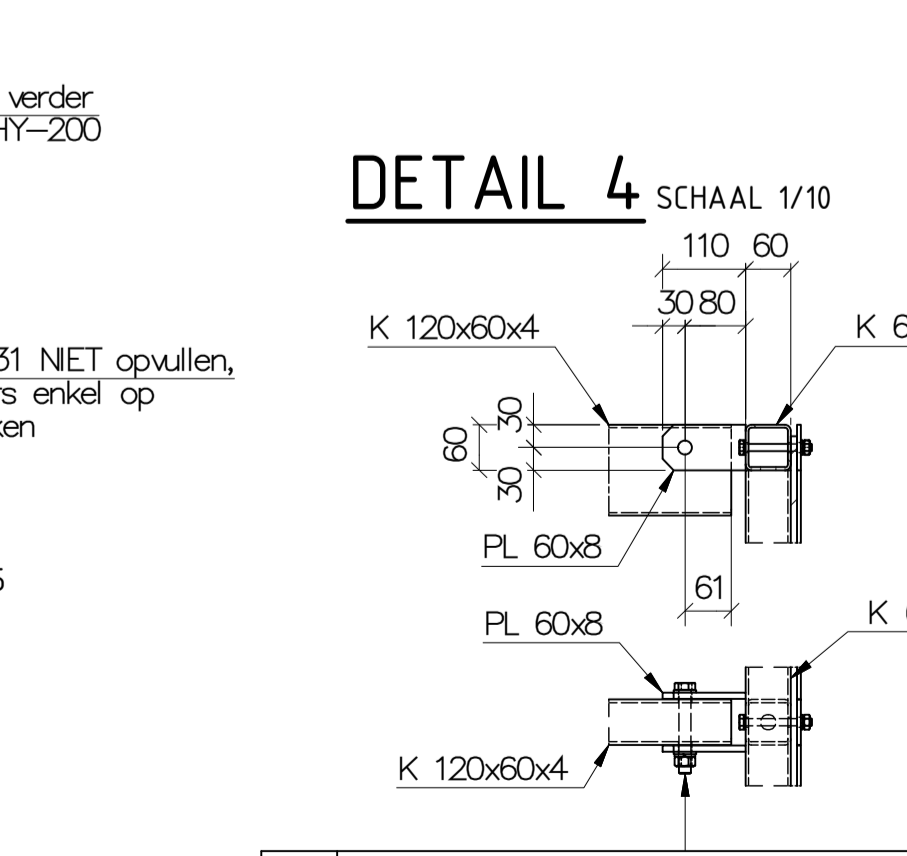
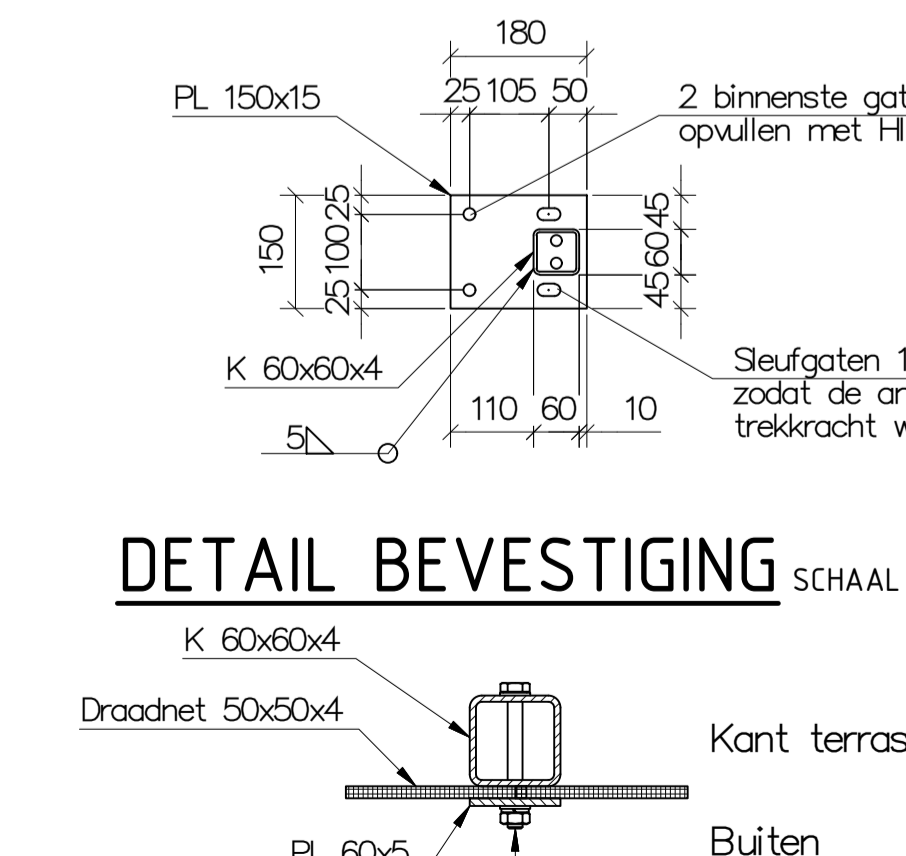
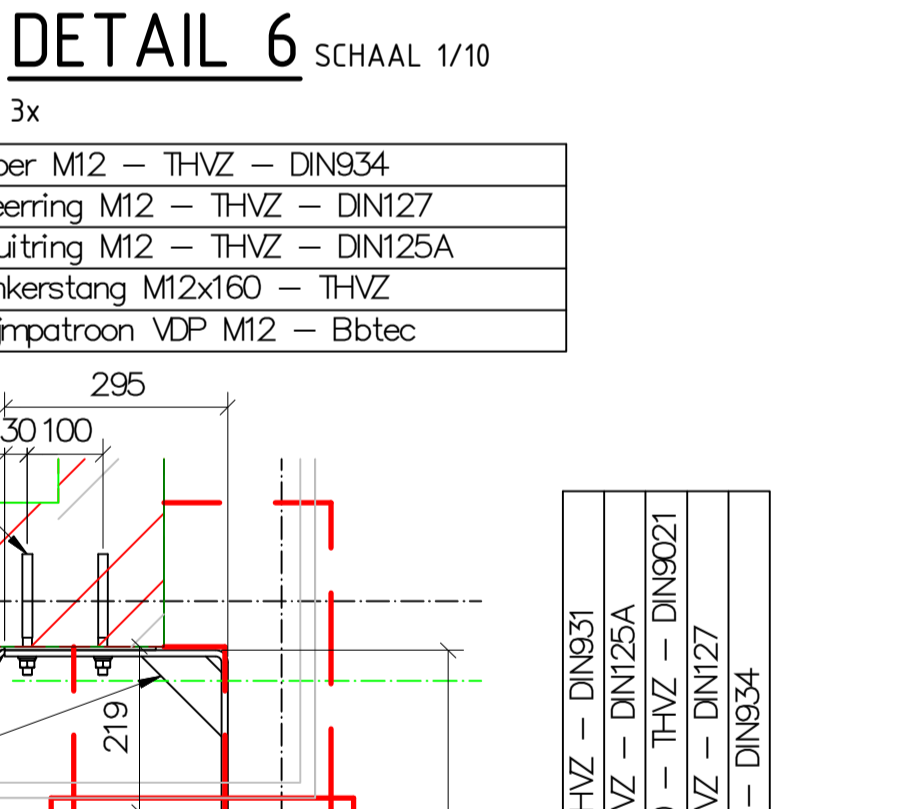
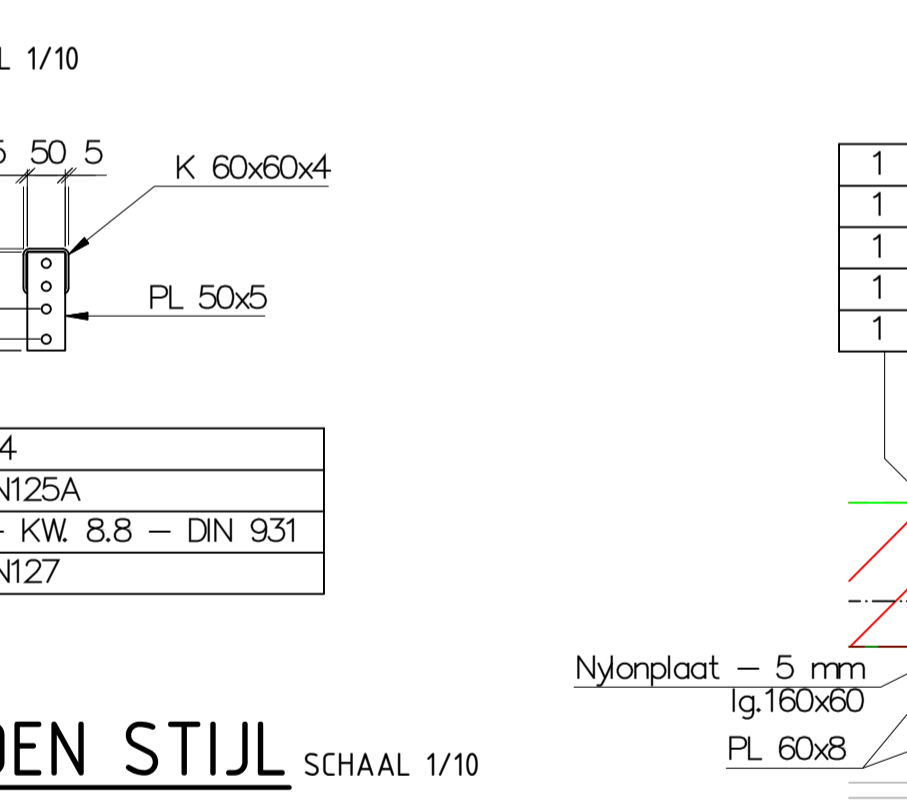
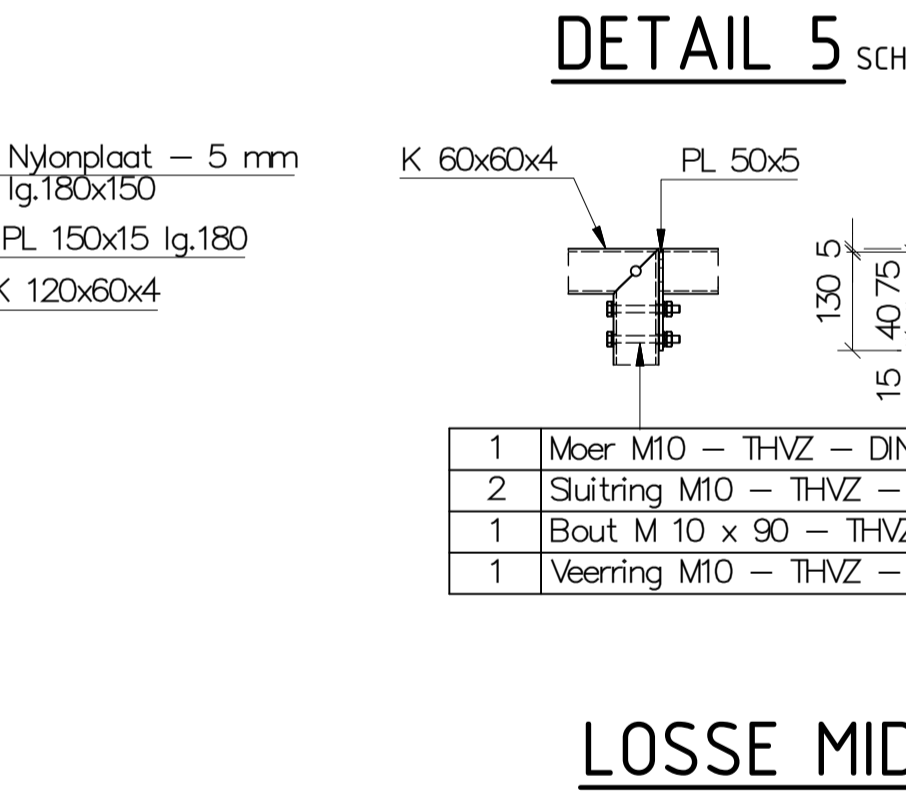
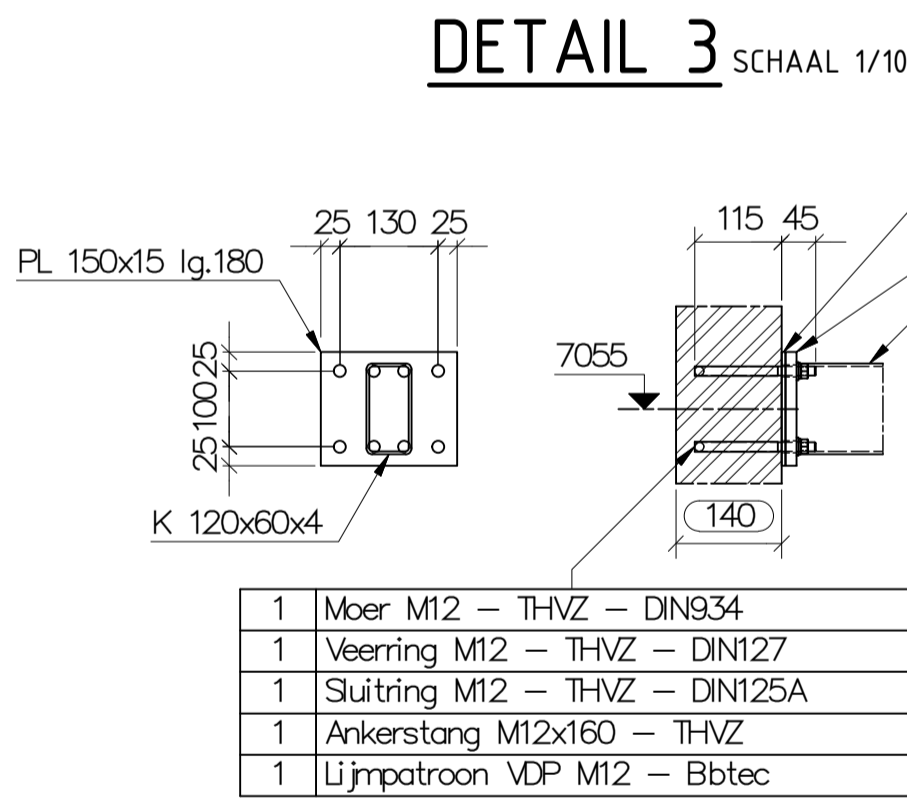
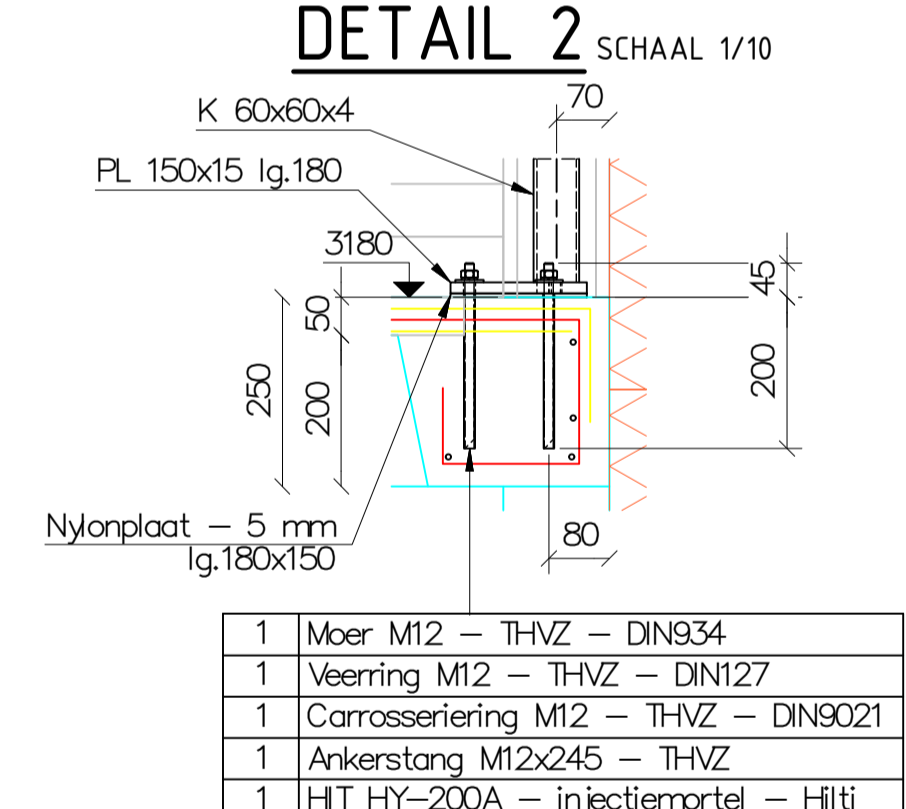
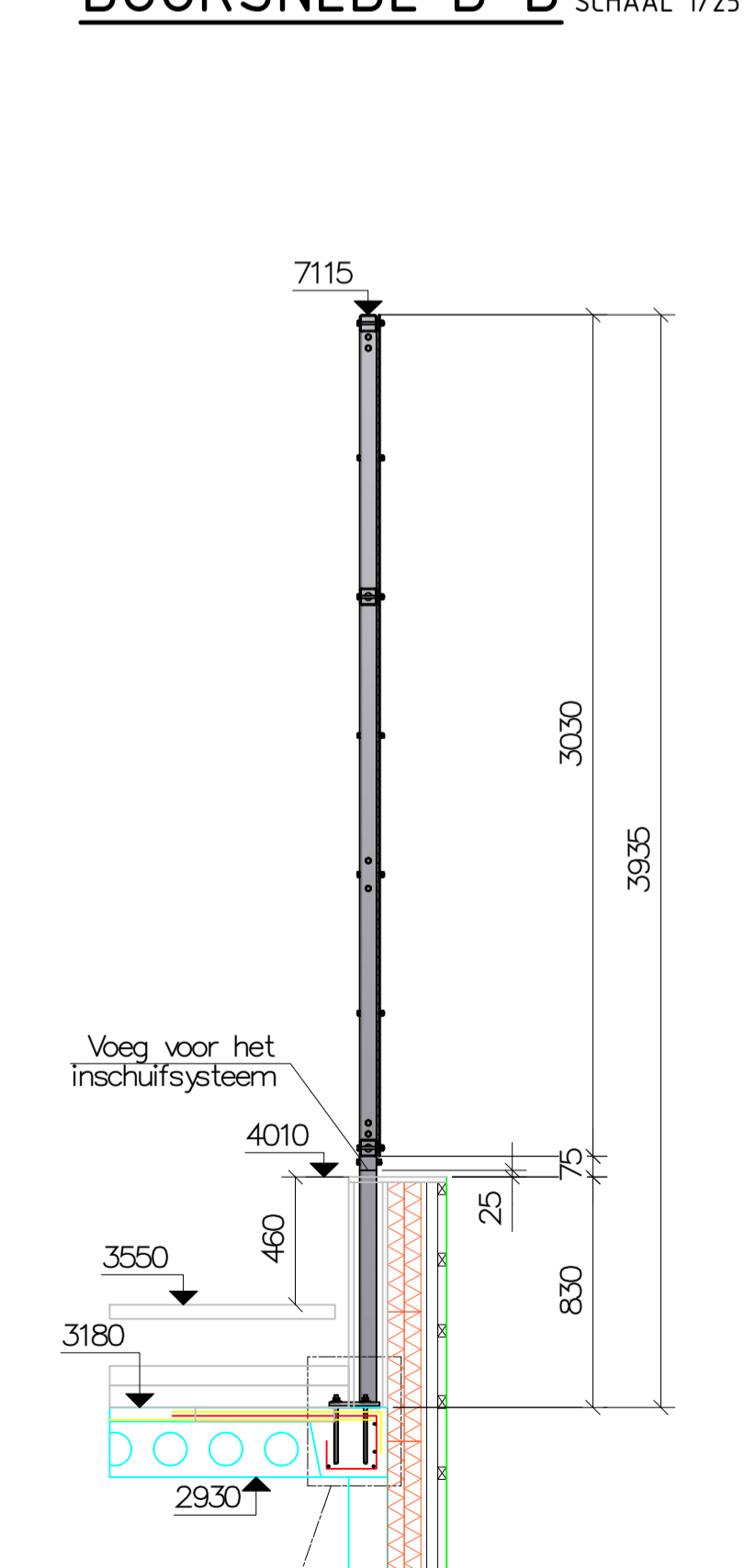
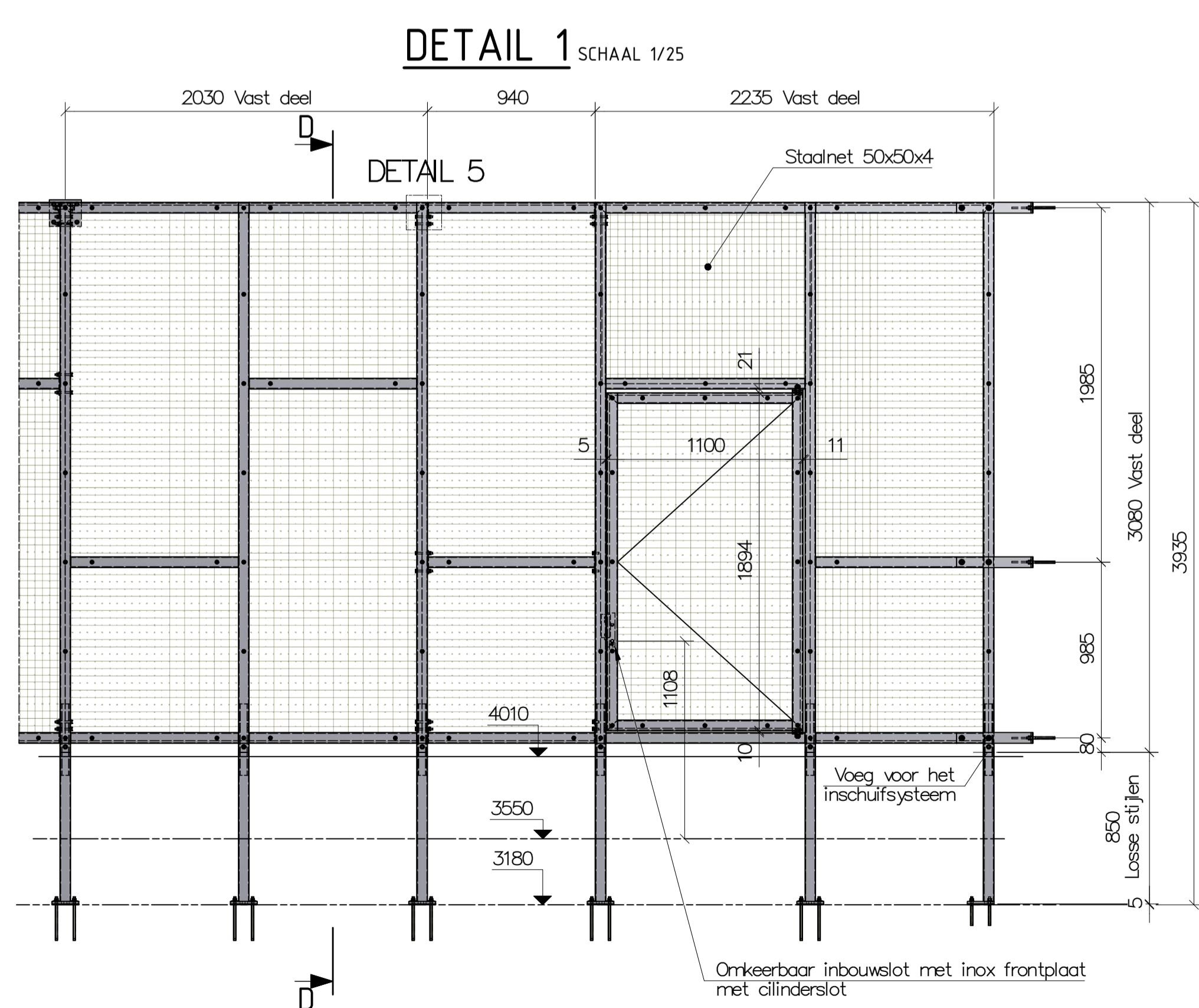

Locatie:

BuBaO / BuSO De Triangel Lovendegem
Molendreef 16
9220 Lovendegem
Oost-Vlaanderen

Algemene aannemer:

DJN ONDERNEMINGEN
JAN DE NUL N.V.

TRAGEL 23
3000 HOEFSTADE - AALST
POSTADRES : POSTBUS 40
3000 AALST
TEL : +32 53 73 15 11
FAX : +32 53 78 15 60
+32 53 77 28 55
E-mail : info@jandnul.com
Website : www.jandnul.com

METAL CONSTRUCTION
VAN EYCKEN

Industrie West-Grèpe, Walstraat 6, 3300 TIENEN Tel : (+32) (0) 16/49.01.01
Fax : (+32) (0) 16/48.81.96

Onderwerp: Omheining dakterras met 1 opengaand deel
Planzicht, doorsnedes en details

Plannr: ve-DR-24092-0501

Get.: GDG Formaat: 1260x594 Ref.:

Datum	Index	Omschrijving
13/05/2015	0	Eerste uitgave
8/06/2015	A	Aanpassing volgens opmerking e-mail DE NUL dd 25/05/2015