



GENERAL GALVANIZING BY FIB BELGIUM

MR RENE BRANDERS CEO

WWW.FIB.BE

FIB Belgium sa

**FIB's offices and factory,
south of Brussels - Belgium**



FIB Belgium sa

Our Group has 5 divisions

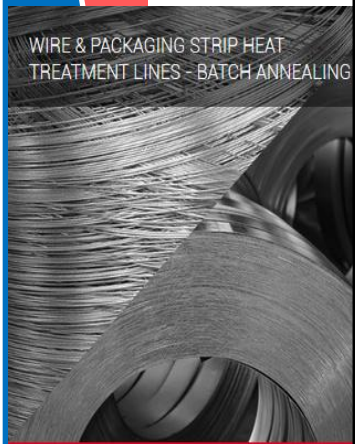

FIB Belgium sa



FIB Belgium sa

Complete automation & process control

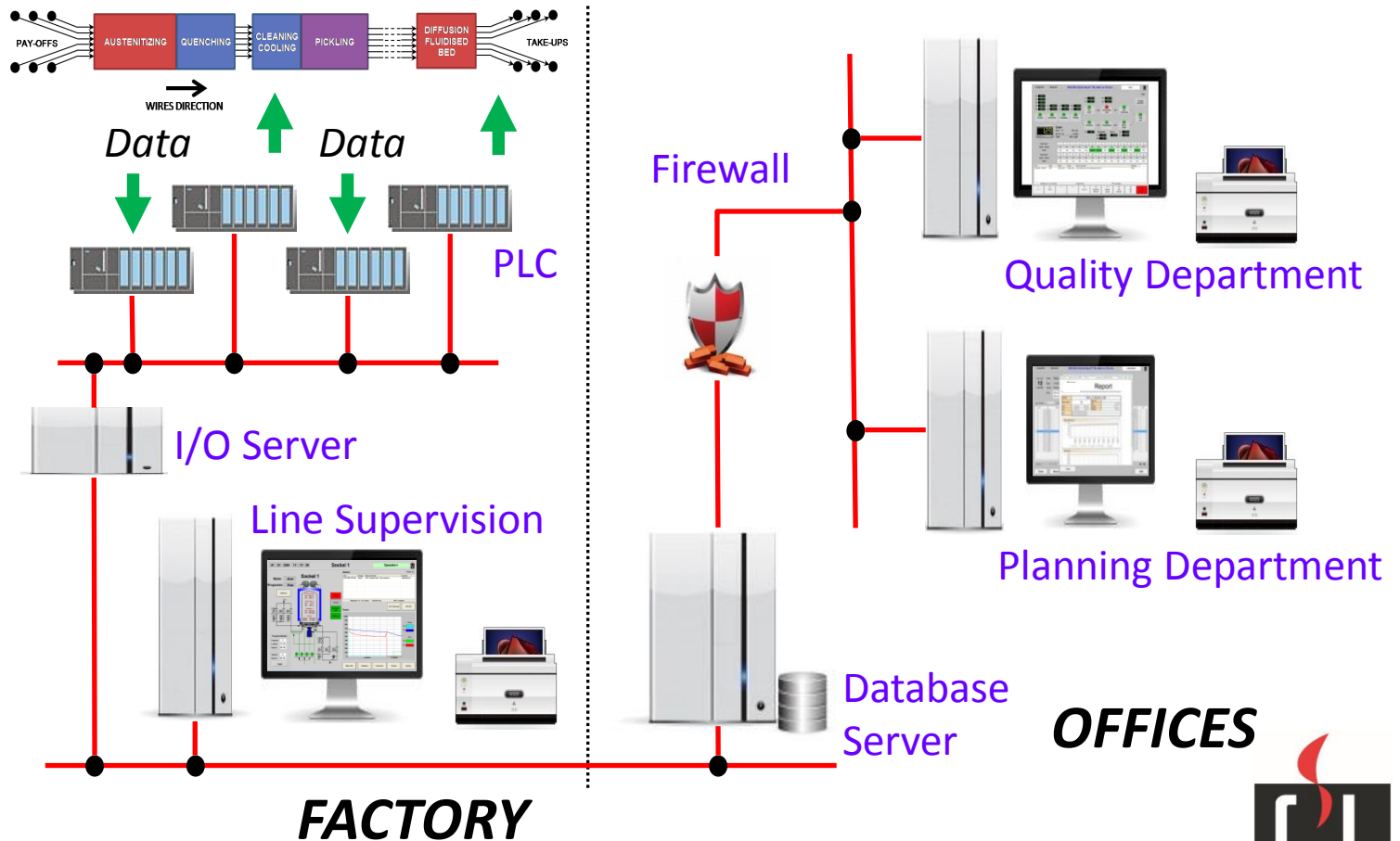

FIB Belgium sa

GENERAL GALVANIZING

WWW.FIB.BE



FIB Belgium sa

General galvanizing at FIB Belgium

- Historical presence of FIB Belgium in the **steel** industry (wire) for 80 years
- Numerous installation of steel **wire** pickling + fluxing + **galvanizing** (continuous process – 140 installations)
- First references came from wire customers to expand towards **general galvanizing**

FIB Belgium sa

Our core activity : the galvanizing thermal part

- **Thermal area**
 - **Galvanizing furnace & combustion systems**
 - **For large items**
 - **For small items (centrifugation)**
 - **Heat recovery system**
 - **High Efficiency Dryers type DRIMFLEX**
 - **Filtration systems**

FIB Belgium sa

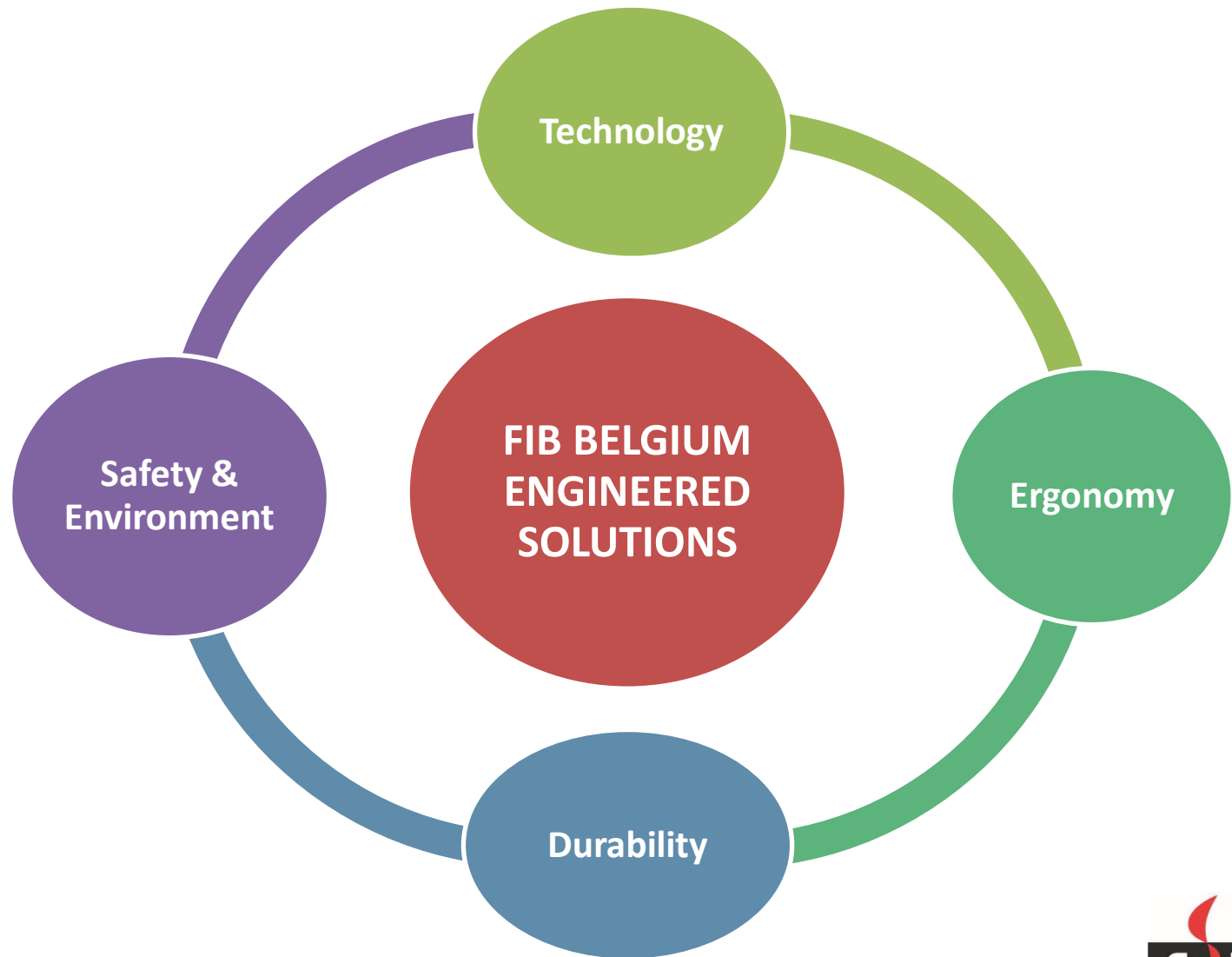

FIB Belgium sa

Our objective : reducing CAPEX and OPEX



FIB Belgium sa

Furnace large items

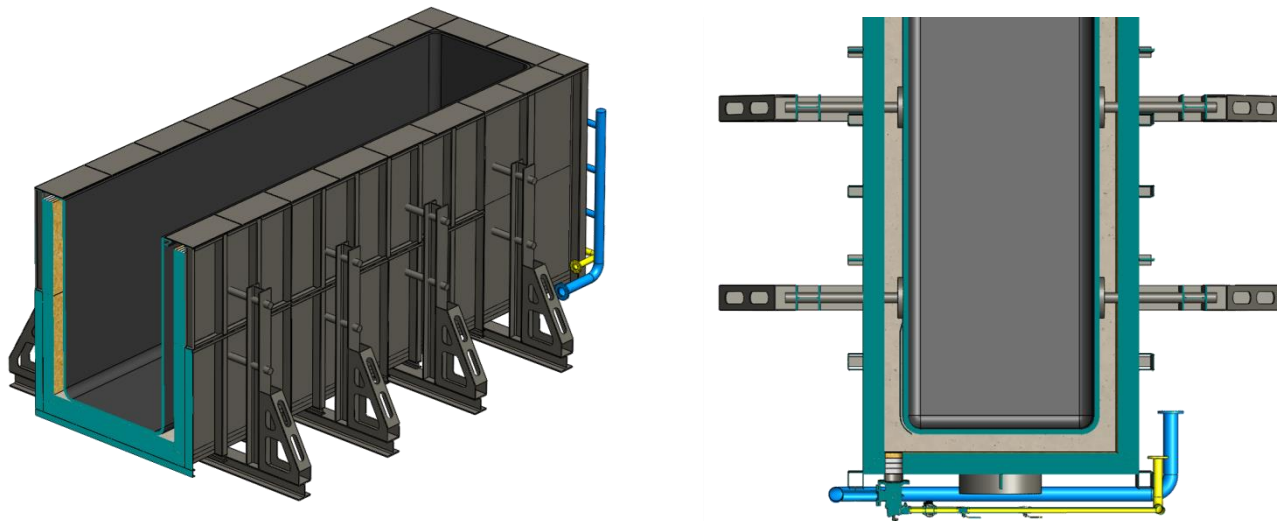

- Engineering – manufacturing – commissioning by FIB Belgium
- Combustion systems : own premix system by FIB Belgium

FIB Belgium sa

Premix combustion systems

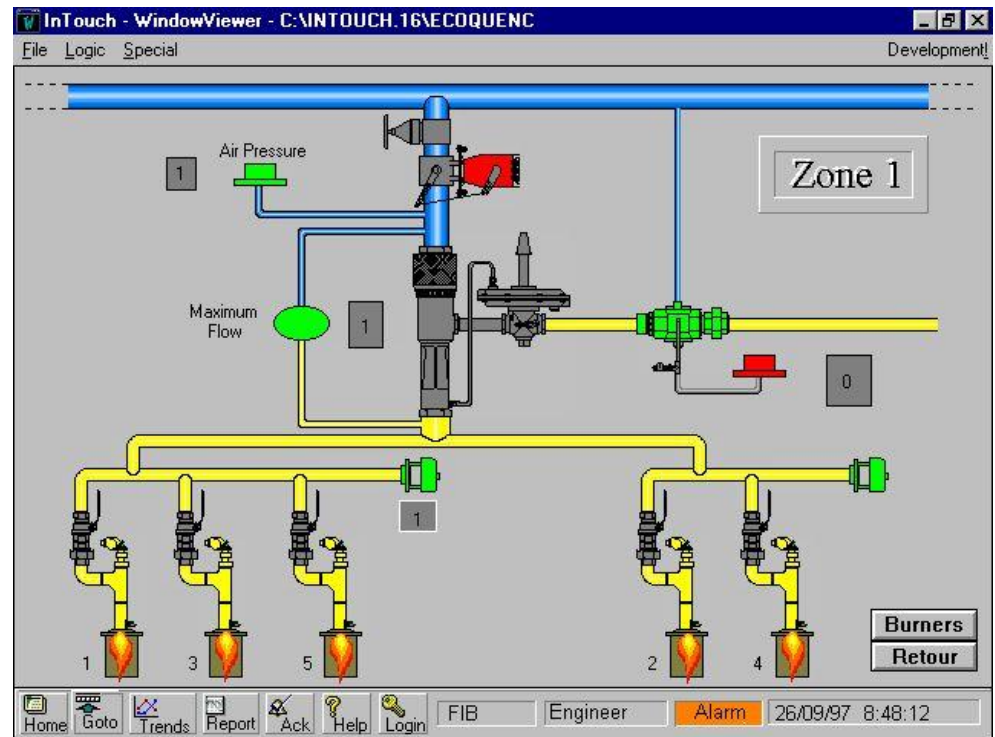

FIB Belgium sa

Furnace + dryer large item

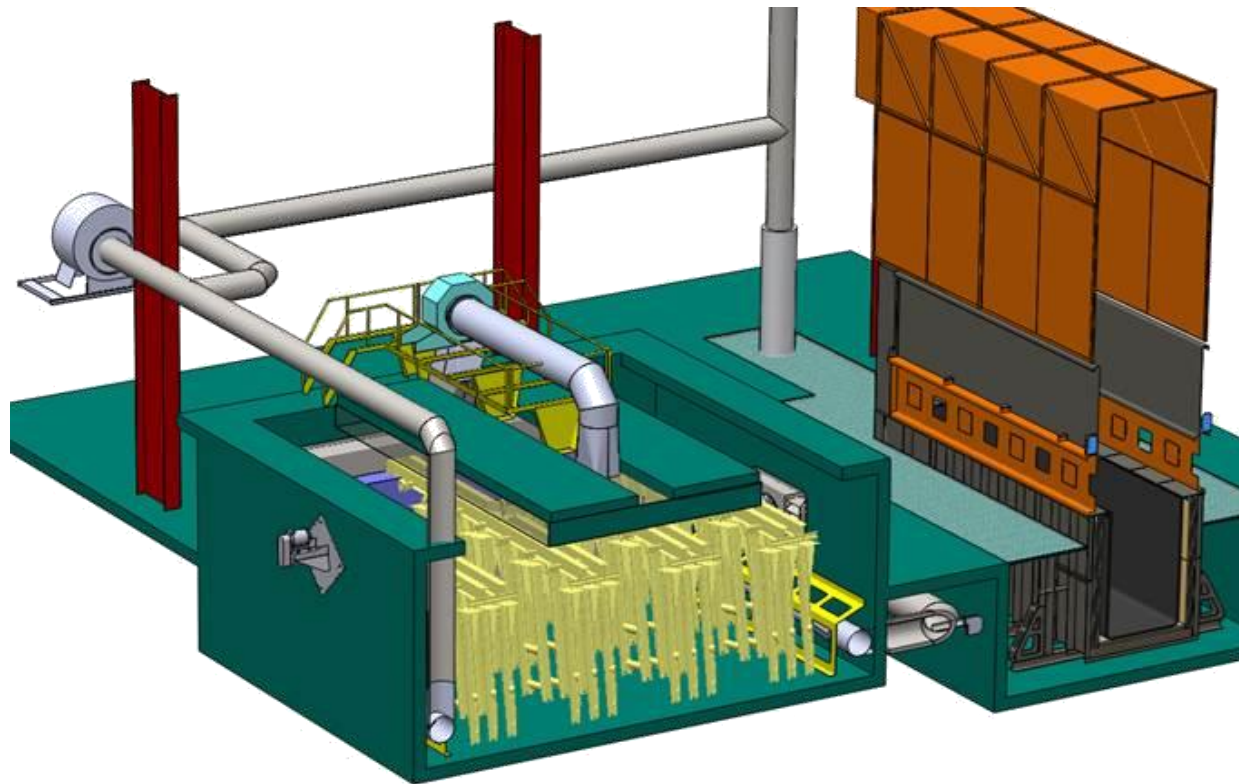

FIB Belgium sa

Dryer large item with lateral doors

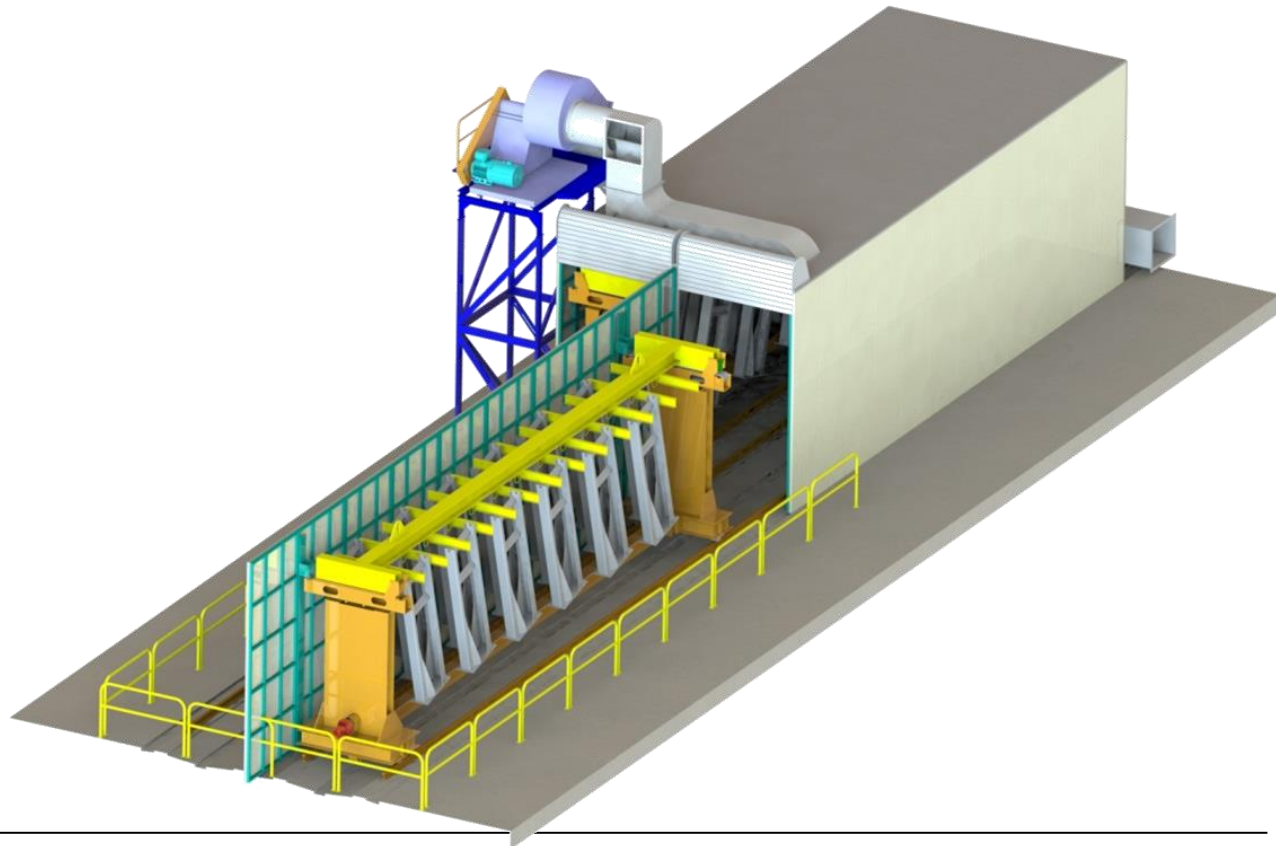

FIB Belgium sa

Centrifugation technology by FIB Belgium

- **Ceramic furnaces**
 - Numerous references in the wire sector
 - High temperatures up to 500-560 C°
 - Alloys Mg-Al

FIB Belgium sa

2 heating technologies

Heating cover

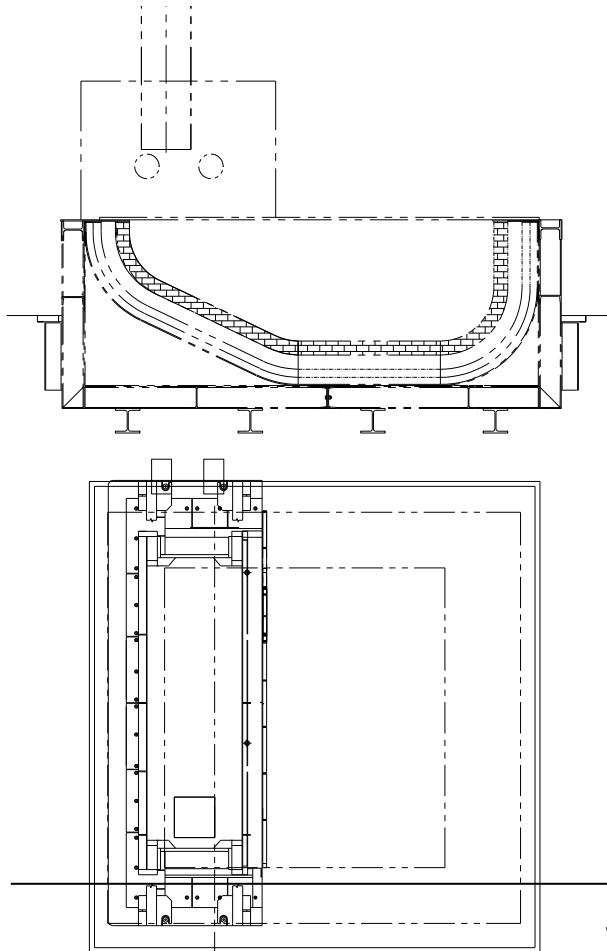

Immersed burners

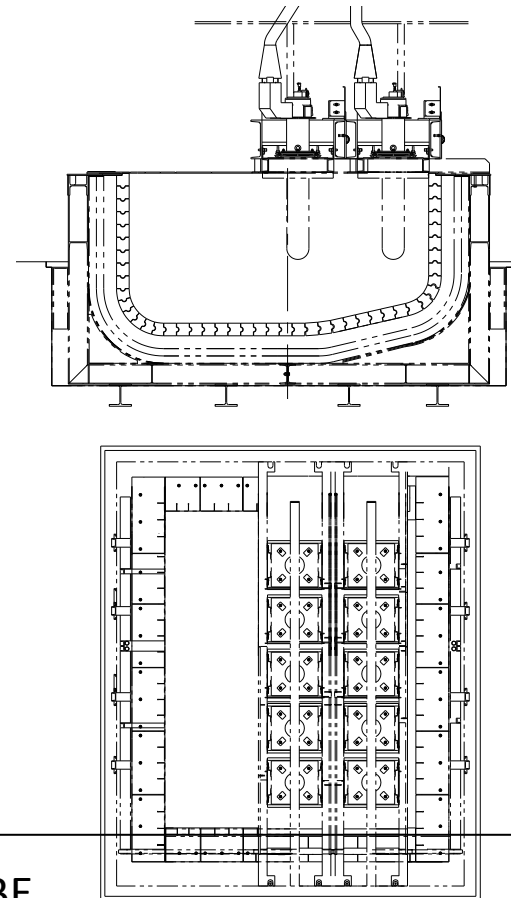

FIB Belgium sa

Immersed gas burners

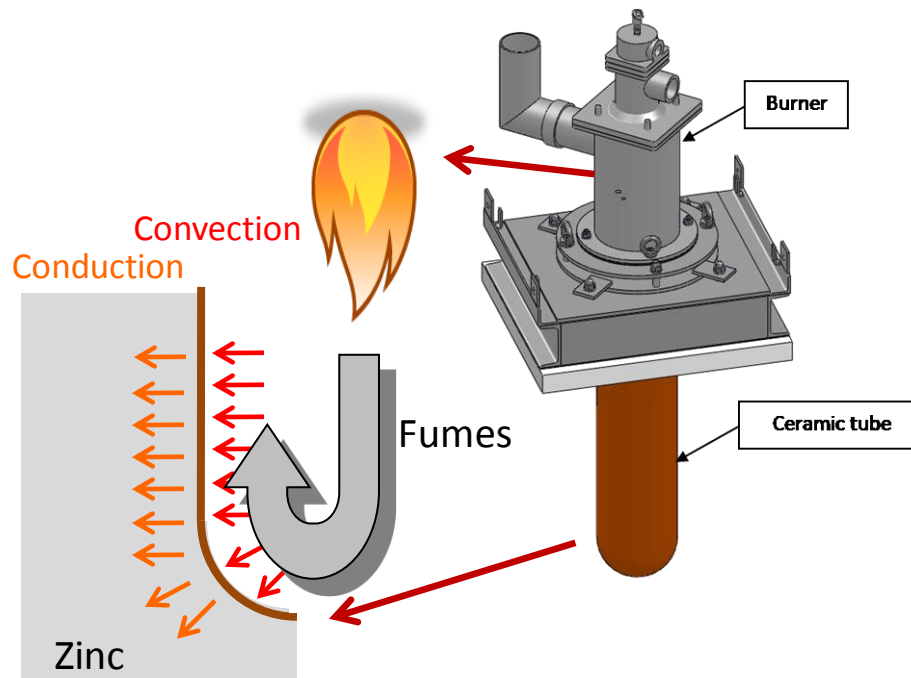

Electric thermoplug

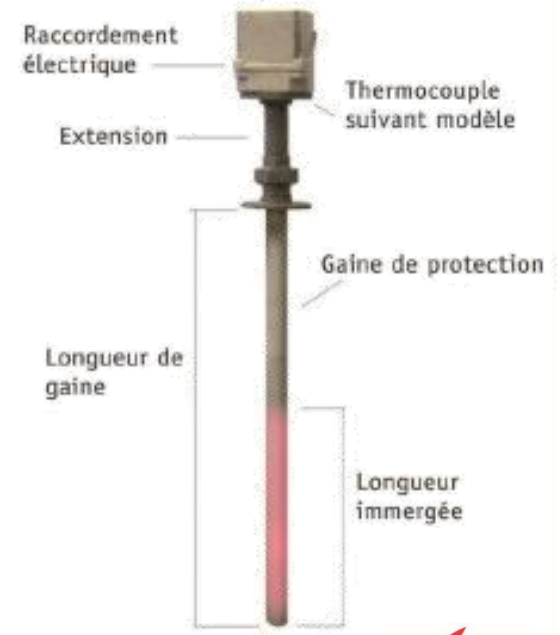

FIB Belgium sa

Immersed burners key success factors

- Immersion = energy gain by min 50%
- User friendly
- CO2 emissions reduction
- Lifetime min 18 months



FIB Belgium sa

Immersed burners lifting system

Operational mode

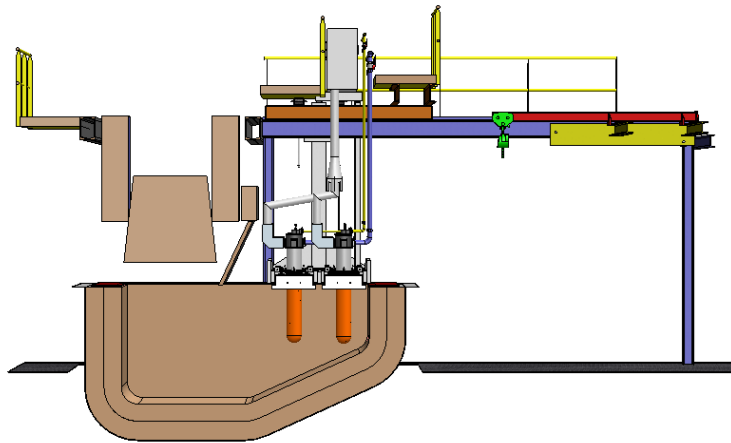

Maintenance mode

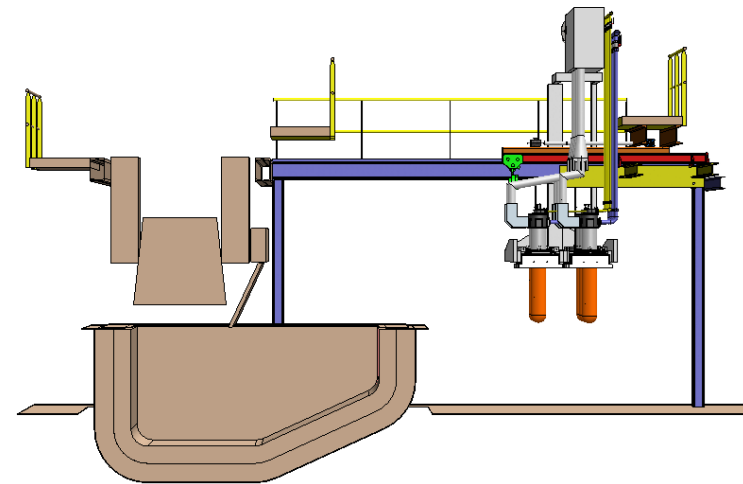

FIB Belgium sa

Immersed burners

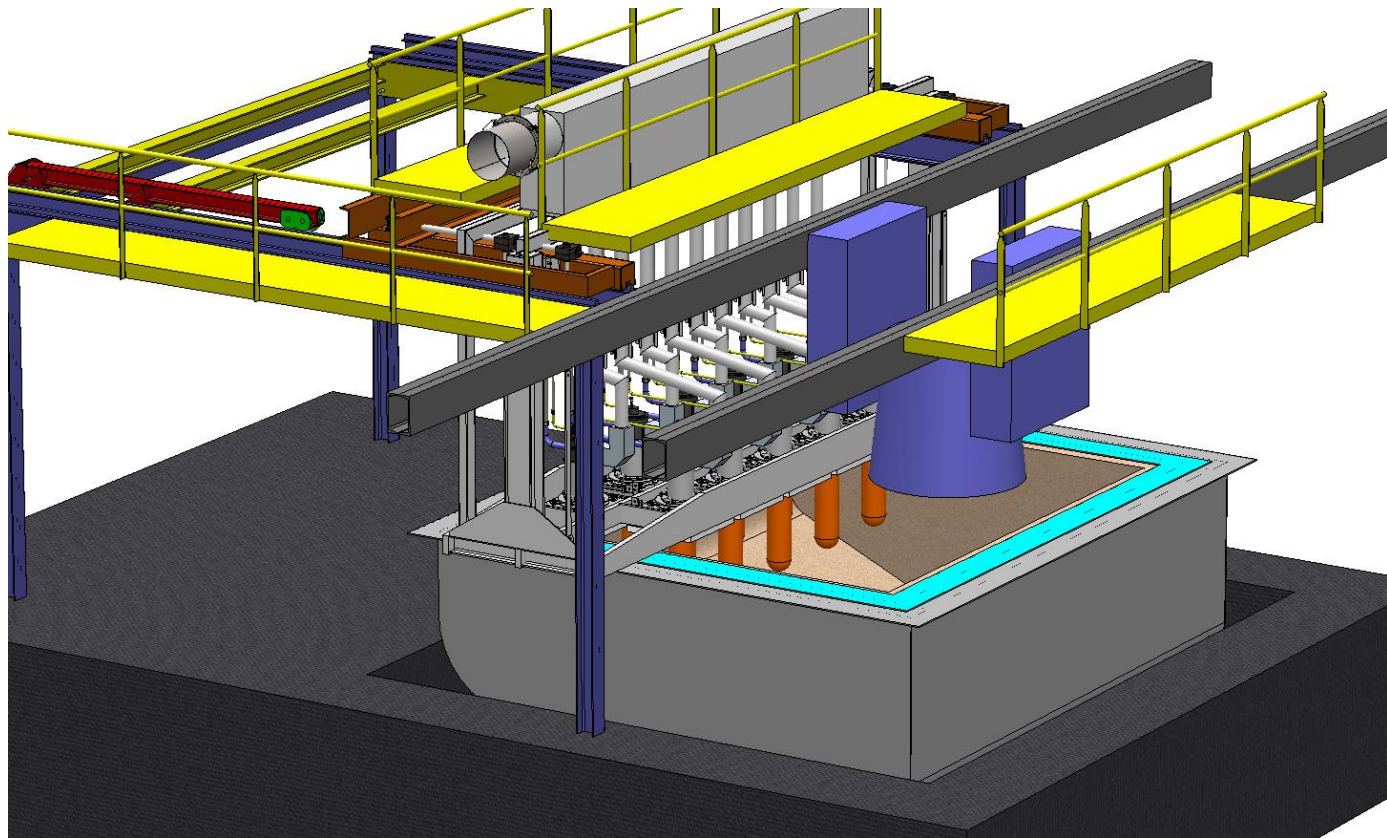

FIB Belgium sa

Immersed burners

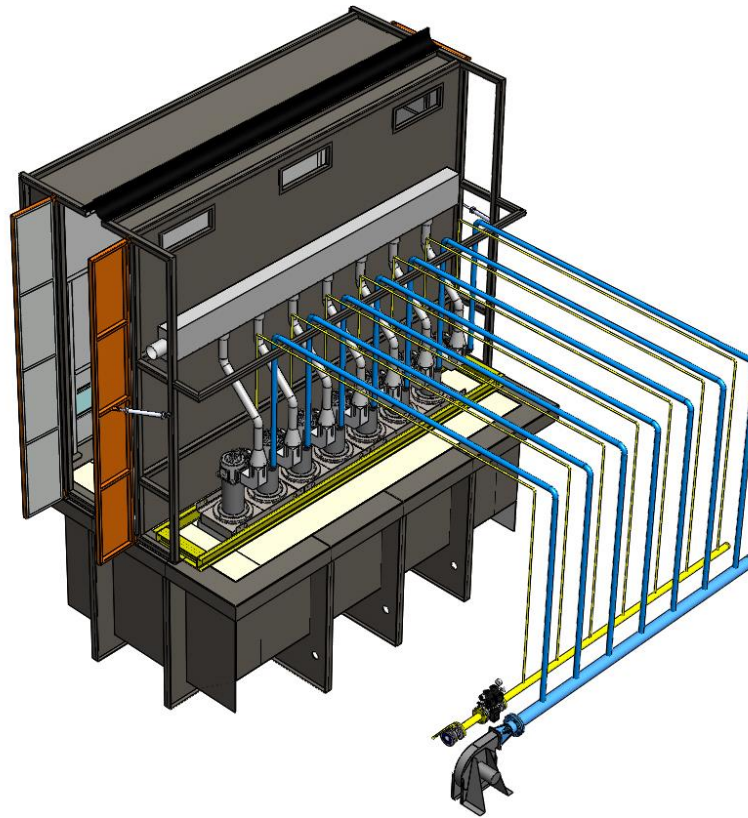

FIB Belgium sa

Complete automatic centrifugation plant

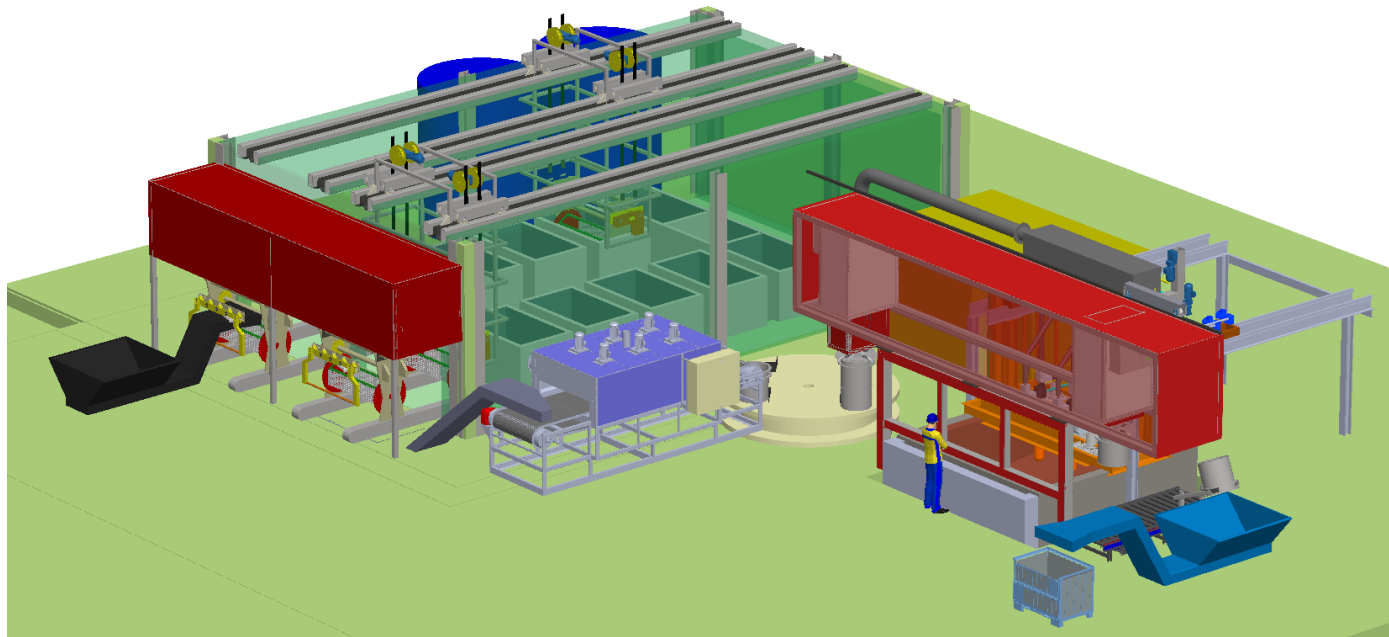

FIB Belgium sa

Our technical audit

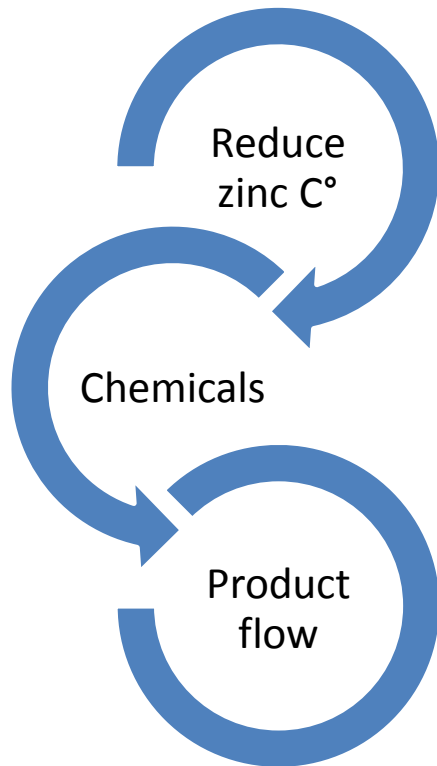

Dryer improvements

- High efficiency dryer
- Upgrade existing dryer

Chemical area improvements

- Flux regeneration
- Amount of baths
- Chemical consultancy

Product flow improvements

- Amount of baths
- Conveying
- Lay out
- Automatisation

FIB Belgium sa

Our industry support

- Member of Zinkinfo (Benelux Galvanizing Association)
- Member of Galvazinc (French Galvanizing Association)
- Member of Institute of Zinc Association (IZA)
- Silver sponsor of Galder Turkey 04-2016
- EGGGA Sevilla 04-2016
- Asia Pacific General Galvanizing Conference 08-2016
- Seminars with Polish Association
- Seminars with Czech and Slovak Association
- EGGGA Prague 06-2017
- Intergalva 2018

FIB Belgium sa

FIB involved in the world economy



Session with Belgian King about export challenges



Session with AGORIA, the Belgian Technology Federation



THANKS A LOT FOR YOUR ATTENTION !

✉ FIB BELGIUM sa, avenue Landas 4 B-1480
TUBIZE-BELGIUM

☎ +32 2 332 17 17 📠 +32 2 376 37 11
info@fib.be

WWW.FIB.BE